

Pilot oil supply

4WEH... and 4WH...

The pilot oil supply is sourced **externally** via channel X from a separate circuit.

The pilot oil drain is led **externally** via channel Y to tank.

4WEH..E..

The pilot oil supply is sourced **internally** from channel P of the main valve.

The pilot oil drain is led **externally** via channel Y to tank. Port X in the subplate is plugged.

Changeover from external to internal or from internal to external pilot oil supply (size 16): Remove the cover on the solenoid side "a", remove the plugs and turn end-for-end, insert plugs and replace the cover.

4WEH..ET..

The pilot oil supply is sourced **internally** from channel P of the main valve.

The pilot oil drain is led **internally** via channel T to tank. Ports X and Y in the subplate are plugged.

4WEH..T..

The pilot oil supply is sourced **externally** via channel X from a separate circuit. The pilot oil drain is led **internally** via channel T to tank. Port Y in the subplate is plugged.

- 1 Plug screw M6 DIN 906–8.8, 3 A/F – pilot oil drain
- 2 Plug screws M6 DIN 906–8.8, 3 A/F – pilot oil supply
- 3 Plug screws M8 x 1 DIN 906–8.8, 4 A/F – for external sealing

Tightening torques M_A for cover fixing screws:

Size 16: 35 Nm

Size 25: 68 Nm

Tightening torque M_A for pilot valve fixing screws:

Sizes 10 to 32: 9 Nm

Throttle insert

The use of a throttle insert is required if the pilot oil supply in the P channel of the pilot valve is to be limited (see page 6, ³). This throttle is inserted in the P channel of the pilot valve.

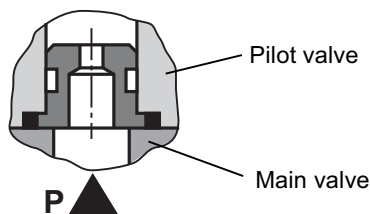

Size 10

Section A – A

Section C – C

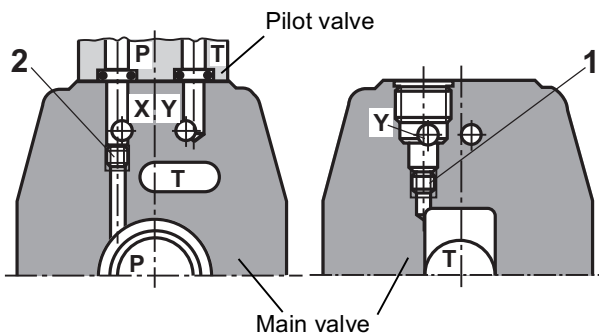

Pilot oil supply
external: 2 plugged
internal: 2 open

Pilot oil drain
external: 1 plugged
internal: 1 open

Size 16

Section D – D

Main valve

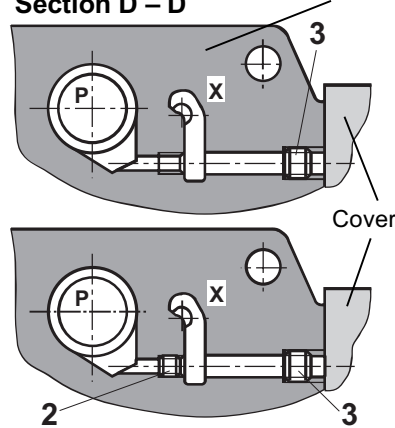

Section C – C

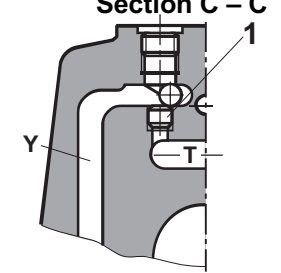

Pilot oil supply
external: 2 plugged
internal: 2 open
Pilot oil drain
external: 1 plugged
internal: 1 open

Size 25 (type 4W.H 22 .7X/...)

Section A – A

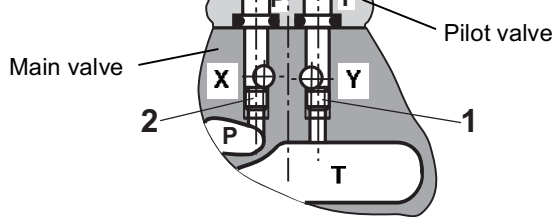

Pilot oil supply
external: 2 plugged
internal: 2 open

Pilot oil drain
external: 1 plugged
internal: 1 open

Size 25 (type 4W.H 25 .6X/...)

Section B – B

Section A – A

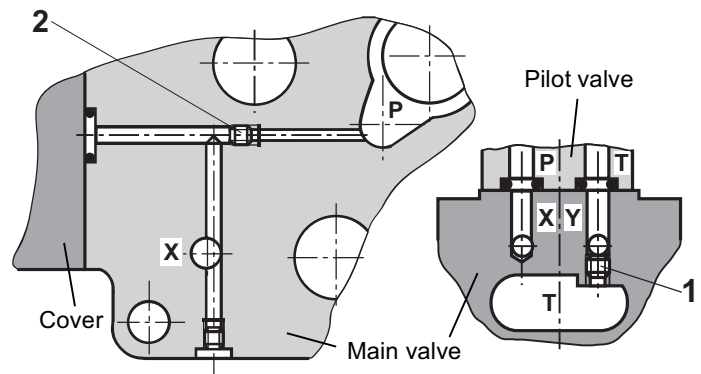

Pilot oil supply
external: 2 plugged
internal: 2 open

Pilot oil drain
external: 1 plugged
internal: 1 open

Size 32

Section A – A

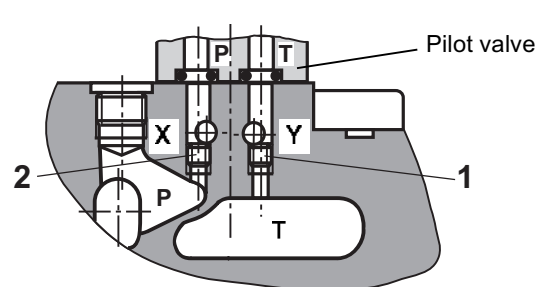

Pilot oil supply
external: 2 plugged
internal: 2 open

Pilot oil drain
external: 1 plugged
internal: 1 open